

12. Adjust Latches (Closure)

From inside garage with door closed, check that latch pin is pulling latch closure plates tightly against lintel (See Fig 9).

- if necessary loosen 2 screws securing latch keep to lintel and adjust latch keep sideways to give correct closure.

- when correct re-tighten screws.

- repeat for other latch if necessary.

13. Important Check for correct operation of latches, using both the internal and external handles. When satisfied, tighten all screws.

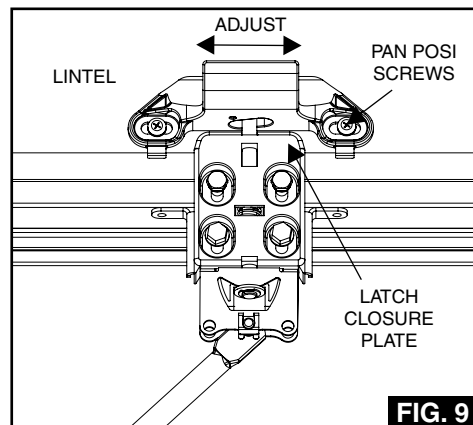

Upon Completion

a) Lubricate the spring, wheel spindles and all pivot points with a '3 in 1' type lubricant.

b) Ensure tracks are clean and door operates smoothly through full open/close cycle.

c) Check door operation to ensure it is correctly balanced. It is the responsibility of the installer to ensure that spring tension is correctly set.

If the tension requires adjustment, refer to maintenance label on the rear of the door.

d) Check that locks and latches operate correctly.

e) Ensure that all fixings are securely tightened.

f) Do not paint the spring or any moving parts.

Canopy - Framed Door Gear

DISMANTLING INSTRUCTIONS

DOOR ONLY

1. Open the door and remove the intermediate screws from the side tracks, leaving the top and bottom fixings in place.
2. Place 12mm packing in two places across the opening, close the door so it is upright and wedged on the packing.
3. Wearing Safety Glasses, grip the Right Hand Pulley with a 22mm A/F Spanner and, by turning upwards, align holes in spring anchor bush and spring shaft. Insert retaining pin (4mm dia x 50mm split pin or similar) fully into this hole as shown, then remove the Spanner (See Fig 5).
4. Remove the lower weather strips.
5. Using cable ties or strong cord or similar, tie the spring assembly securely to the door's latch brackets.
6. Remove the 4 screws that secure the two spring mounting brackets.
Important: DO NOT let the spring shaft assembly drop down uncontrolled.
7. Prop the door securely in position.
8. Remove the top and bottom fixings from the tracks including the security block. Tracks are now loose and can be tied to the door panel with cable ties or similar.
9. Remove the top latch keeps/spring support brackets from the lintel (See Fig 7).
10. Wearing Safety Gloves, by removing the props, the door can now be carefully removed from the opening. Seek assistance in lifting.

DOOR AND FRAME

1. Remove any sealant from around the frame.
2. If available, refit transit plate (See Fig 4). If not use suitable piece of wood and fix as transit plate.
3. Wearing Safety Glasses and with door closed, insert the retaining pin into the spring assembly (See Fig 5).
4. Remove wall mounting and floor fixing brackets which will allow the door and frame to be moved. Leave one screw per side securely fixed until assistance is at hand and you are ready to move the door and frame assembly.

**THESE INSTRUCTIONS MUST BE FOLLOWED CAREFULLY.
GARAGE DOORS ARE AWKWARD AND HEAVY TO HANDLE.
ENSURE ASSISTANCE IS AVAILABLE AND THAT SAFETY GLOVES ARE WORN.**

Canopy - Framed Door Gear

INSTALLATION INSTRUCTIONS

This garage door has been designed to be as easy as possible to use, service and automate when installed correctly. Please therefore take time to read these instructions fully before beginning any work.



SAFETY FIRST

Please read instructions right through before commencing installation.

CAUTION

The spring is under tension - follow instructions carefully to avoid any chance of personal injury.

IMPORTANT INFORMATION

1. The door and components must be installed by suitably trained and qualified persons, in accordance with the instructions provided. If in doubt contact a professional installer.
2. This garage door is intended for domestic use only.
3. Garage doors are heavy and may have sharp edges. Wear protective gloves. Installation should not be undertaken alone. Care must be taken when handling.
4. Ensure the door is continuously supported before it is secured and avoid installing in windy conditions.
5. Wear Eye protection.

WARNING - When fitting the multi-point latching do not shut the door whilst you are outside the garage until all latches have been correctly set and tested (See instructions). Failure to comply could result in being locked out of the garage and a chargeable service call will be required.

IMPORTANT NOTES - BEFORE COMMENCING WORK: Remove all wrapping including plastic sleeve from spring and any carry straps. Ensure that your door has been supplied with the correct main fixing pack (fixing pack codes are on the identification label on reverse of door). Remove lock pack / fixing pack from transit position on the rear of the door. All the initial work is carried out from inside the garage so tools and parts should be to hand before door is placed in the opening.

FITTING TO BRICKWORK

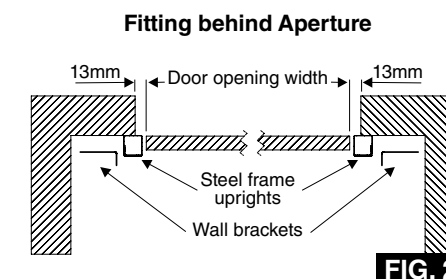
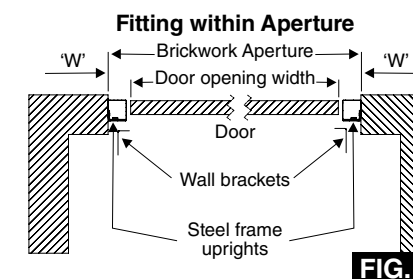

Steel Frame Dimensions

Width 'W' - The steel frames are available with frame uprights in two widths.
When fitting } W = 54mm Brickwork aperture = Door opening width + 108mm + 6mm clearance
'within aperture' } W = 68mm Brickwork aperture = Door opening width + 136mm + 6mm clearance

Lintel height - Lintel height is always 68mm - **Brickwork aperture** = Door opening height + 68mm + 3mm clearance

Frame thickness - All 3 elements of 'Goalpost' frame are 60mm deep

INSIDE VIEW OF DOOR & GUIDE TO INSTRUCTIONS

YOU WILL NEED

22mm A/F spanner	Tape measure
8mm A/F socket/spanner	Grease
10mm A/F socket/spanner	'3 in 1' type oil
Posi screwdriver (Z3 & Z2)	Engineer's pliers
Protective gloves	Spirit level
Eye protection	Wedges (packing pieces)
Sharp knife	

NOTE A

NO WALL PLUGS ARE PROVIDED.
IT IS THE RESPONSIBILITY OF THE INSTALLER TO PROVIDE AND FIT WALL PLUGS SUITABLE FOR THE STRUCTURE TO WHICH THE DOOR IS TO BE FITTED.

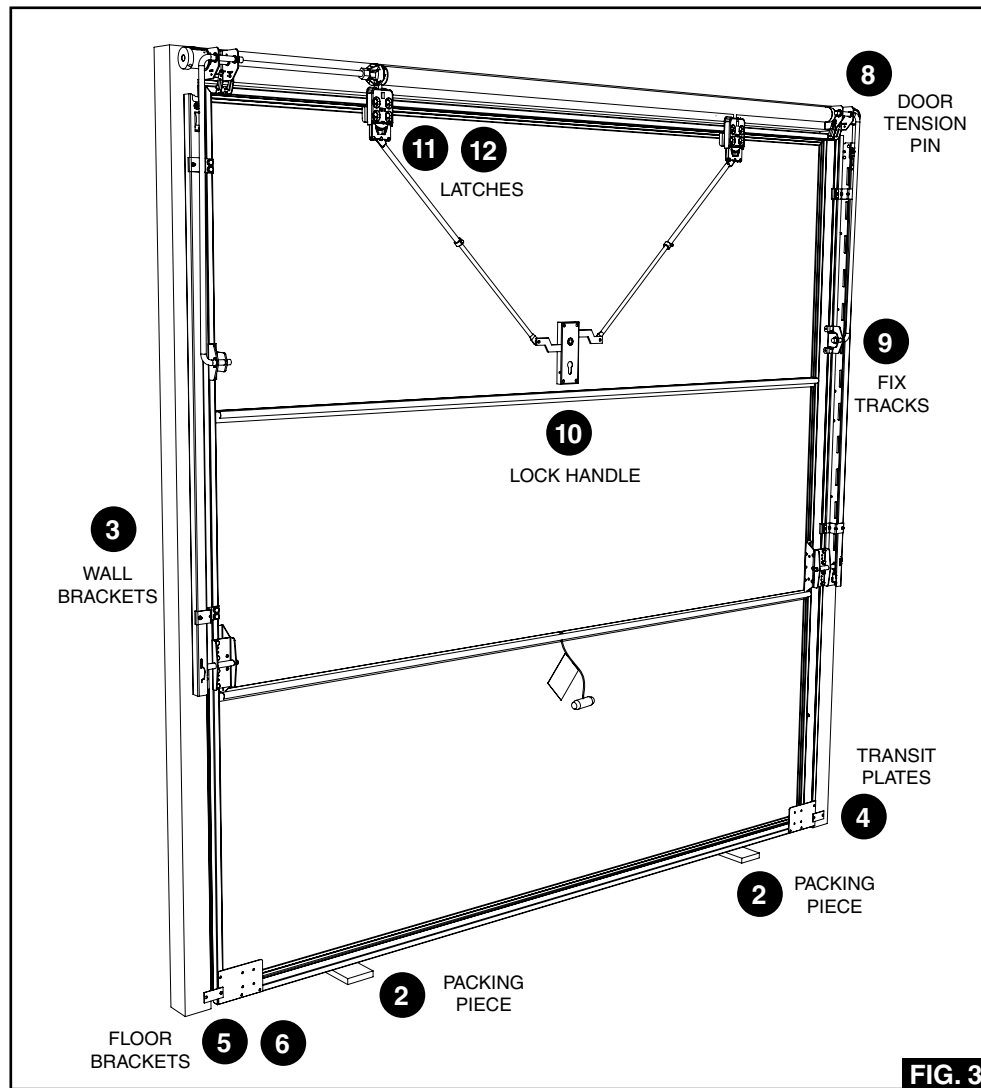

FIG. 3

Prior to Installation

1. Select fixing positions and assemble wall brackets, fixing finger tight to frame using appropriate screws as specified below.

A. For fitting frame within aperture, brackets should be fitted to back face of frame as shown in Figure 1 on front page as follows:

i. Fit lower wall fixing brackets to both legs of frame using 2 off No. 14 x 1" hex head self tap screws per bracket.

ii. Fit top wall fixing brackets to both legs of frame:-

- on **54mm wide legs** slide slotted leg of bracket into gap in edge of frame and fix with 2 off M6 posi screws with lock washers and plain washers per bracket.

- on **68mm wide legs** place bracket on frame leg and bolt through with 2 off M6 hex head sem screws and plain washers per bracket.

NOTE: There is a maximum of 19mm (3/4") side adjustment on each bracket when fitting between brickwork.

B. For fitting frame behind aperture, brackets should be fitted to side of frame, as shown in Figure 2 on front page, as follows:

i. Fit lower wall fixing brackets using 2 off No. 14 x 1" hex HD self tap screws per bracket.

ii. Fit top wall fixing brackets using 2 off M6 hex HD sem screws and plain washers per bracket.

NOTE: For fitting frame behind aperture it may be necessary to cut the wall brackets down to clear any side walls or pillars.

2. Place door unit central in aperture wedging in position if necessary (See Fig 3).

IMPORTANT: Use spirit level to ensure that door/frame are level and square.

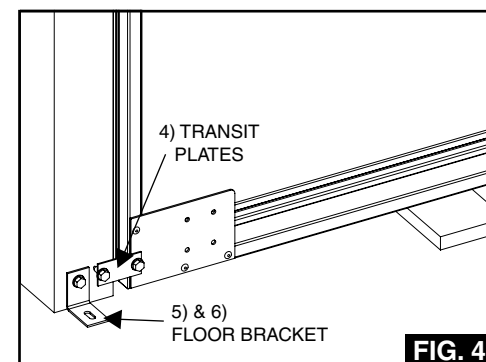

FIG. 4

3. Fix brackets to wall. Secure using 1 off M8 x 50mm coach screw and M8 washer provided per bracket and with suitable wall plugs (See Note A).

4. Remove transit plates from bottom of assembly (See Fig 4) and discard.

5. Fit floor brackets to frame using No. 14 x 1" hex HD self tap screw, 1 off per bracket (See Fig 4).

6. Fix floor brackets to floor (See Fig 4). Secure using 1 off M8 x 50mm coach screw and M8 washer provided per bracket and with suitable wall plugs (See Note A).

7. Check for final position and adjust if necessary. Ensure frame is square and vertical and that door is central with an equal parallel gap either side. **Tighten up screws in all brackets.**

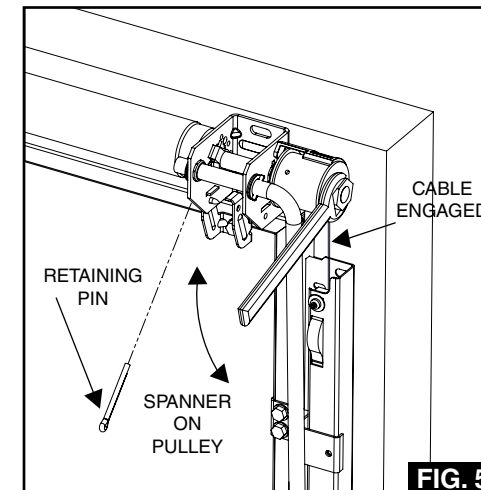

FIG. 5

8. Put Tension on Door

IMPORTANT: Ensure cables are within Tracks and correctly engaged in grooves on Pulleys and into Wheel Spindle Clips on BOTH sides of door.

Remove the retaining pin from the Spring Anchor Bush (at RH end) using a 22mm A/F spanner on the pulley, push upwards slightly and pull out the retaining pin using pliers (See Fig 5), you now have tension on the door.

9a. Open / close door through full travel to test track position and door operation. If necessary make final adjustments to Tracks for correct operation.

9b. With door fully open insert 5 screws per side (No.8 x 1" pan posi self tap) down each track.

9c. Fully tighten all Track fixing screws.

CAUTION: Do not close door from outside until lock handle is fitted and all latches have been checked for correct settings and operation. Failure to follow these instructions may result in a lock out situation and a chargeable service call may result.

10. Fit Lock

Check that there is a black spacer bush fitted into face of door.

a) If supplied, fit fascia plate to front of door.

b) Remove the screw and washer from the outer handle (See Fig 6) and pass the handle spindle through the lock as shown.

c) Fit the inner handle and secure using the screw and washer just removed. DO NOT OVERTIGHTEN.

NOTE: Latches have been pre-fitted but should be checked and adjusted if necessary

11. Adjust Latches (Engagement)

From inside garage with door fully closed, check that latch pin has approximately 6mm engagement in latch keep (See Fig 7).

If insufficient or excessive engagement:-

- loosen adjuster screw on lock bars.
- loosen off 4 Hex HD screws securing latch body to door (See Fig 8).
- move latch body vertically on slots until correct 6mm engagement is achieved.
- re-tighten 4 Hex HD screws.
- Ensure bell crank is flush with latch body (See Fig 8) and re-tighten lock bar adjuster screw.
- repeat for other latch pin if necessary.

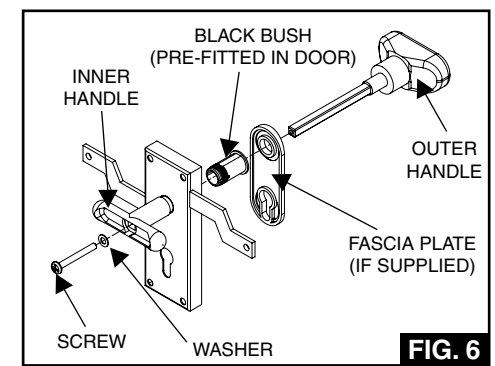

FIG. 6

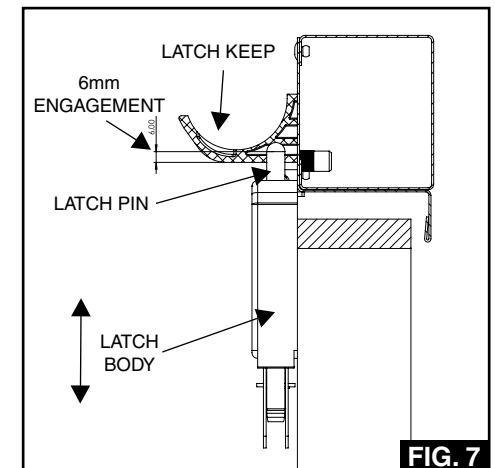

FIG. 7

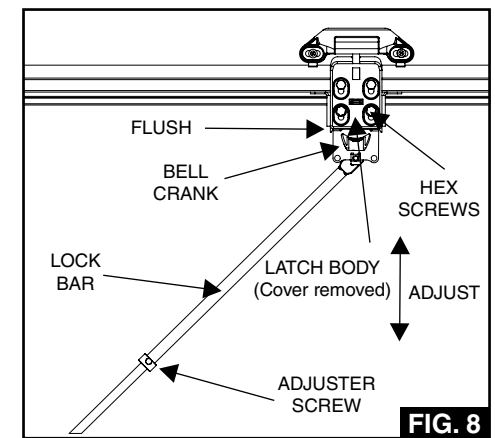

FIG. 8